

LED SURFACE LIGHT

Product&Family Code:

016 059 0032

CARLA/SQ-32

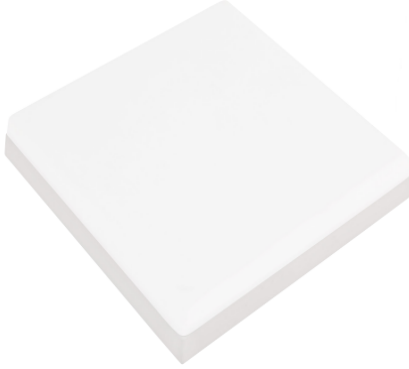

WHITE

Technical Drawing

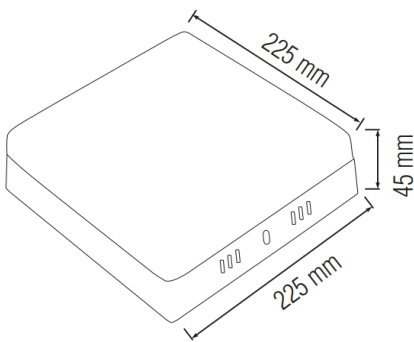

Technical Data

Voltage (V)	100-265V
Product Wattage (W)	32
Equivalence with incandescent lamp	256
Colour Render Index (Ra)	>70
Colour Temperature (K)	3000K/4200K/6400K
Materials	PP
Protection Class	II
Dimmable	No
EEL	-
Warm-up time up to 60 %of the full light output	Instant Full Light
Luminous Flux (lm)	3040
Luminous Efficacy (lm/W)	95
Rated Life (hrs) Ⓢ	25.000
IP Rating	20
Power Factor	>0.5
Beam Angle	120°
Starting Time	<0.2s
Number of ON-OFF cycling	x12.500

Applications

Airport, Bathroom, Bedroom, Car Park, Cinema, Gallery, Hospital, Hotel, Kitchen, Museum etc.



Features

- High Lumen and CRI, Good quality & Constant Current driver.
- High heat dissipation, low carbon and environmental protection.
- Innovative design of assembly structure.
- Extremely Long Life.

